



History-Based Value Report

History events affecting this vehicle's value



1

1-Owner Vehicle



Open Recall



Minor Damage

\$29,020 Retail Value



Vehicle History Report™

US \$44.99

**2021 FORD EXPLORER
HYBRID POLICE
INTERCEPTOR UTILITY**

VIN: 1FM5K8AW8MNA06876
4 DOOR WAGON/SPORT
UTILITY
3.3L V6 F DOHC 24V
HYBRID
REAR WHEEL DRIVE W/ 4X4
Original Window Sticker

Accident reported: minor damage

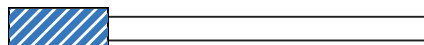

MINOR MODERATE SEVERE



2 Service history records



At least 1 open recall







CARFAX 1-Owner vehicle



15,166 Last reported odometer reading

This CARFAX Vehicle History Report is based only on information supplied to CARFAX and available as of 1/20/24 at 7:27:54 AM (CST). Other information about this vehicle, including problems, may not have been reported to CARFAX. Use this report as one important tool, along with a vehicle inspection and test drive, to make a better decision about your next used car.

 Ownership History The number of owners is estimated		Owner 1
Year purchased		2021
Type of owner		---
Estimated length of ownership		3 years
Owned in the following states/provinces		Michigan
Estimated miles driven per year		6,527/yr
Last reported odometer reading		15,166

 Title History CARFAX guarantees the information in this section		Owner 1
Damage Brands Salvage Junk Rebuilt Fire Flood Hail Lemon		<input checked="" type="checkbox"/> Guaranteed No Problem
Odometer Brands Not Actual Mileage Exceeds Mechanical Limits		<input checked="" type="checkbox"/> Guaranteed No Problem
 GUARANTEED - None of these title problems were reported by a U.S. state Department of Motor Vehicles (DMV). If you find that any of these title problems were reported by a DMV and not included in this report, you may qualify. View Terms View Certificate		

 Additional History Not all accidents / issues are reported to CARFAX		Owner 1
Total Loss No total loss reported to CARFAX.		<input checked="" type="checkbox"/> No Issues Reported
Structural Damage CARFAX recommends that you have this vehicle inspected by a collision repair specialist.		<input checked="" type="checkbox"/> No Issues Reported
Airbag Deployment No airbag deployment reported to CARFAX.		<input checked="" type="checkbox"/> No Issues Reported
Odometer Check No indication of an odometer rollback.		<input checked="" type="checkbox"/> No Issues Indicated
Accident / Damage Accidents reported: 03/27/2023 and 07/20/2023.		Minor Damage

Manufacturer Recall	At least 1 manufacturer recall requires service. Locate an authorized Ford or Lincoln Mercury dealer or call 866-436-7332 to obtain more information about this recall.	Recall Reported
Basic Warranty	Original warranty estimated to have 0 months or 20,834 miles remaining. Confirm with dealer or vehicle manufacturer.	<input checked="" type="checkbox"/> Warranty Active



Detailed History



Owner 1
Purchased: 2021



Low mileage! This owner drove less than the industry average of 15,000 miles per year.

6,527 mi/yr

Date	Mileage	Source	Comments	
01/11/2021		Ford Motor Company	Vehicle manufactured and shipped to original dealer	
	Original Window Sticker			
01/11/2021	3	Lunghamer Auto Sales Owosso, MI 989-447-2908 sigautogroup.com ★ 4.6 / 5.0 88 Verified Reviews ♥ 1,727 Customer Favorites		Vehicle serviced Pre-delivery inspection completed
01/14/2021	Michigan Motor Vehicle Dept.		Vehicle purchase reported	
01/20/2021	10	Michigan Motor Vehicle Dept. East Lansing, MI Title #MI0008039104	Title issued or updated First owner reported	
03/27/2023	Damage Report			Accident reported: minor damage It hit a utility pole Damage to rear



CARFAX HAS THE MOST ACCIDENT & DAMAGE INFORMATION

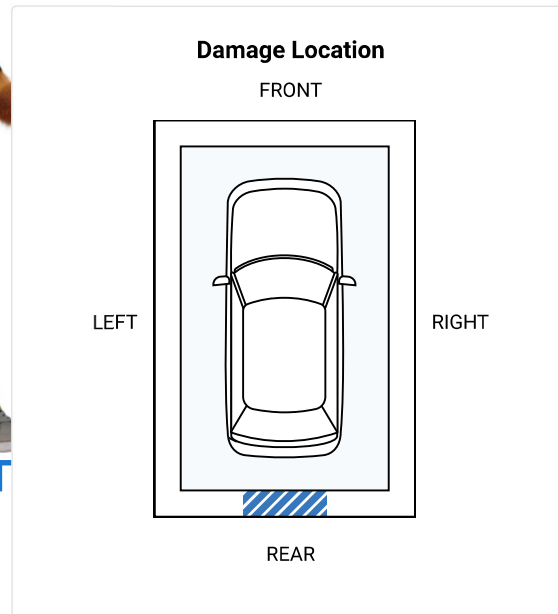
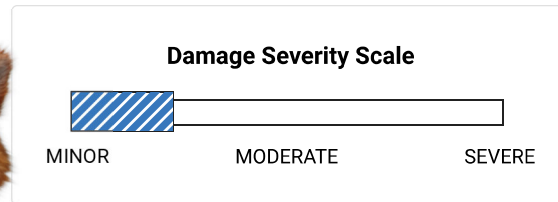

Minor damage is usually cosmetic, including dents or scratches to the vehicle body.

05/12/2023 15,166

Morrie's Ford Okemos
Okemos, MI
517-347-1830
<https://morriesokemosford.com>
/?utm_source=gmb&utm_medium=social&mcmid=gmb

★ 4.8 / 5.0
23 Verified Reviews
♥ 6 Customer Favorites



Vehicle serviced

- Maintenance inspection completed
- Brakes checked
- Fluids checked
- Tire condition and pressure checked

07/20/2023

Damage Report



Accident reported: minor damage
Damage to left front



CARFAX HAS THE MOST ACCIDENT & DAMAGE INFORMATION

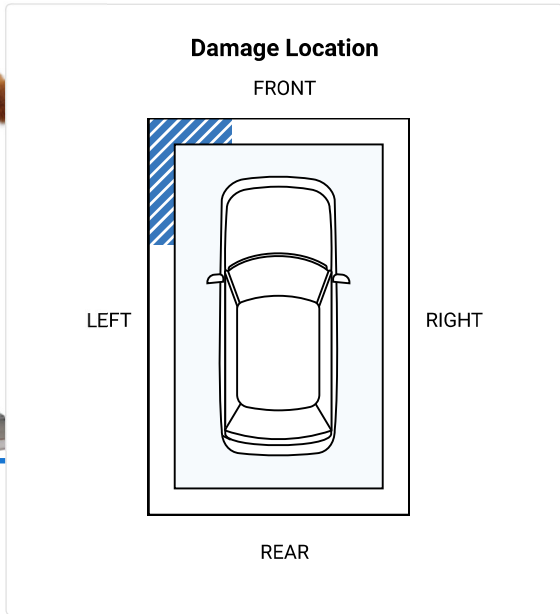
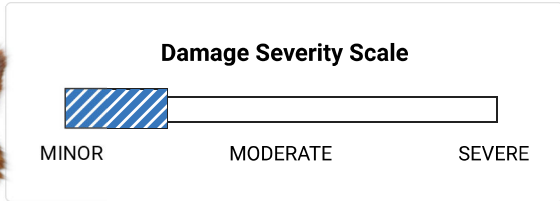

Minor damage is usually cosmetic, including dents or scratches to the vehicle body.

10/09/2023

Ford Motor Company

Manufacturer Safety recall issued

NHTSA #23V675

Recall #23S55 REAR AXLE BOLT FRACTURES

Status: Remedy Available

Locate an authorized Ford or Lincoln dealer or call 866-436-7332 to obtain more information

⊖ **Learn more about this recall**

Description: ON YOUR VEHICLE, A REAR AXLE BOLT MAY FRACTURE.

IF YOUR VEHICLE WAS PREVIOUSLY REPAIRED FOR THIS ISSUE UNDER RECALL 22S27 TO APPLY THE ELECTRONIC PARKING BRAKE WHEN THE VEHICLE IS SHIFTED TO PARK, A FURTHER REPAIR IS NEEDED TO PREVENT REAR AXLE BOLT FRACTURE. A FRACTURED REAR AXLE BOLT WILL ALLOW THE REAR AXLE HOUSING TO MOVE OUT OF POSITION, RESULTING IN SEVERE NOISE AND VIBRATION. IF THE REAR AXLE BOLT BREAKS, THE DRIVESHAFT OR HALF-SHAFTS MAY BECOME DISCONNECTED, RESULTING IN LOSS OF TRANSMISSION TORQUE TO THE REAR WHEELS. TRANSMISSION TORQUE IS NECESSARY TO HOLD THE VEHICLE IN PARK AND IS ALSO NEEDED FOR THE VEHICLE TO MOVE FORWARD OR BACKWARD. LOSS OF THE VEHICLES FORWARD POWER INCREASES THE RISK OF CRASH AND INJURY. THE LOSS OF THE PRIMARY PARK TORQUE WILL ALLOW THE VEHICLE TO ROLL IN PARK IF THE PARKING BRAKE IS NOT APPLIED, INCREASING THE RISK OF CRASH AND INJURY.

Remedy: PARTS ARE NOW AVAILABLE TO REPAIR YOUR VEHICLE. FORD MOTOR COMPANY HAS AUTHORIZED YOUR DEALER FOR THE REPAIR OF THE REAR AXLE BOLTS FREE OF CHARGE PARTS AND LABOR.

Have Questions? Consumers, please visit our Help Center at www.carfax.com. Dealers or Subscribers, please visit our Help Center at www.carfaxonline.com.



Glossary

First Owner

When the first owner(s) obtains a title from a Department of Motor Vehicles as proof of ownership.

Ownership History

CARFAX defines an owner as an individual or business that possesses and uses a vehicle. Not all title transactions represent changes in ownership. To provide estimated number of owners, CARFAX proprietary technology analyzes all the events in a vehicle history. Estimated ownership is available for vehicles manufactured after 1991 and titled solely in the US including Puerto Rico. Dealers sometimes opt to take ownership of a vehicle and are required to in the following states: Maine, Massachusetts, New Jersey, Ohio, Oklahoma, Pennsylvania and South Dakota. Please consider this as you review a vehicle's estimated ownership history.

Title Issued

A state issues a title to provide a vehicle owner with proof of ownership. Each title has a unique number. Each title or registration record on a CARFAX report does not necessarily indicate a change in ownership. In Canada, a registration and bill of sale are used as proof of ownership.

Follow Us:



[facebook.com/CARFAX](https://www.facebook.com/CARFAX)



[@CARFAXinc](https://twitter.com/CARFAXinc)



[About CARFAX](#)

CARFAX DEPENDS ON ITS SOURCES FOR THE ACCURACY AND RELIABILITY OF ITS INFORMATION. THEREFORE, NO RESPONSIBILITY IS ASSUMED BY CARFAX OR ITS AGENTS FOR ERRORS OR OMISSIONS IN THIS REPORT. CARFAX FURTHER EXPRESSLY DISCLAIMS ALL WARRANTIES, EXPRESS OR IMPLIED, INCLUDING ANY IMPLIED WARRANTIES OF MERCHANTABILITY OR FITNESS FOR A PARTICULAR PURPOSE.

© 2024 CARFAX, Inc., part of S&P Global. All rights reserved.

1/20/24 7:27:54 AM (CST)

I have reviewed and received a copy of the CARFAX Vehicle History Report for this 2021 FORD EXPLORER HYBRID vehicle (VIN: 1FM5K8AW8MNA06876), which is based on information supplied to CARFAX and available as of 1/20/24 at 8:27 AM (EST).

Customer Signature	Date	Dealer Signature	Date
---------------------------	-------------	-------------------------	-------------