



# Report

US \$44.99

## 2004 Toyota 4Runner Limited

114,394 mi | VIN: JTEBU17R748022474 |

4 Door Wagon/Sport Utility | 4.0L V6 F DOHC 24V | Gasoline | All wheel drive

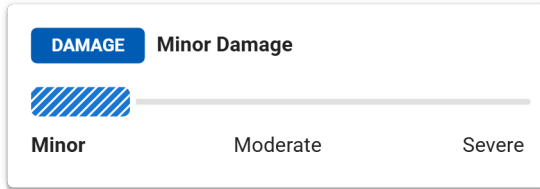

**CARFAX VALUE** \$12,150

7 Service history records

At least 1 open recall

CARFAX 1-Owner vehicle

Personal vehicle

Last owned in District of Columbia

This CARFAX Vehicle History Report is based only on information supplied to CARFAX and available as of 4/6/26 at 2:16:37 PM (CDT). Other information about this vehicle, including problems, may not have been reported to CARFAX. Use this report as one important tool, along with a vehicle inspection and test drive, to make a better decision about your next used car.



## Accident / Damage History

Not all accidents / issues are reported to CARFAX

### Event 1

07/27/2020

Damage reported: minor damage

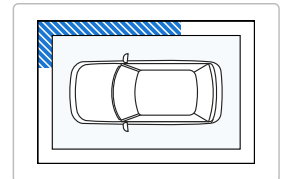
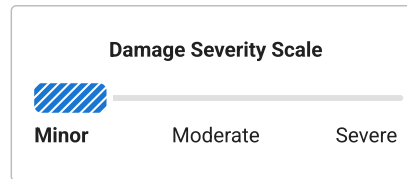

### Event 2

07/02/2021

Damage reported: minor damage

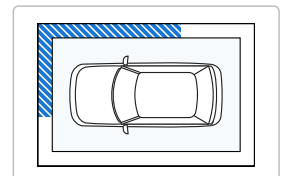
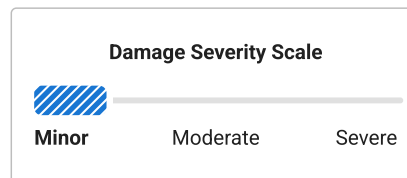

### Event 3

08/01/2024

Damage reported: minor damage

Damage Severity Scale

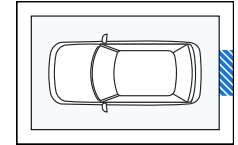
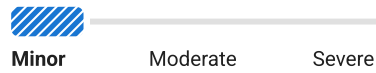

**CARFAX** History-Based Value Report

**\$12,150**

CARFAX Retail Value

History events affecting this vehicle's value

- 1-Owner Vehicle
- Personal Vehicle
- Open Recall
- Minor Damage

**CARFAX** Additional History

Not all accidents / issues are reported to CARFAX

Owner 1

**Total Loss**

No total loss reported to CARFAX.

No Issues Reported

**Structural Damage**

CARFAX recommends that you have this vehicle inspected by a collision repair specialist.

No Issues Reported

**Airbag Deployment**

No airbag deployment reported to CARFAX.

No Issues Reported

**Odometer Check**

No indication of an odometer rollback.

No Issues Indicated

**Accident / Damage**

Damage reported: 07/27/2020, 07/02/2021, and 08/01/2024.

Minor Damage

**Manufacturer Recall**

At least 1 manufacturer recall requires service. Locate an authorized Toyota dealer near you to schedule an appointment. View Toyota disclosure

Recall Reported

**Basic Warranty**

Original warranty estimated to have expired.

Warranty Expired

**CARFAX** Title History

Owner 1

**Damage Brands**

Salvage | Junk | Rebuilt | Fire | Flood | Hail | Lemon

No Problem

**Odometer Brands**

Not Actual Mileage | Exceeds Mechanical Limits

No Problem

**CARFAX** Ownership History

The number of owners is estimated

Owner 1

Year purchased

2004

Type of owner

Personal

Estimated length of ownership

21 yrs. 9 mo.



**1 OWNER**

Owned in the following states/provinces	District of Columbia
Estimated miles driven per year	5,647/yr
Last reported odometer reading	114,394





**CARFAX** Detailed History

 **Owner 1**  
Purchased: 2004



**Low mileage!** This owner drove less than the industry average of 15,000 miles per year.

Personal Vehicle  
5,647 mi/yr

Date	Mileage	Source	Comments
03/29/2004		NICB	<b>Vehicle manufactured and shipped to original dealer</b>
06/22/2004		D.C. Inspection Station Washington, DC	<b>Passed emissions inspection</b>
06/22/2004	5	D.C. Motor Vehicle Dept. Washington, DC Title #K1157834	<b>Title issued or updated</b> - Registration issued or renewed - First owner reported - Titled or registered as personal vehicle
06/21/2005		D.C. Motor Vehicle Dept. Washington, DC Title #K1157834	<b>Registration issued or renewed</b>
06/06/2007		D.C. Inspection Station Washington, DC	<b>Passed emissions inspection</b>
06/06/2007		D.C. Motor Vehicle Dept. Washington, DC Title #K1157834	<b>Registration issued or renewed</b>
02/09/2009	33,262	Jim Coleman Toyota Bethesda, MD 301-469-7100 jimcolemantoyota.com ★ 4.7 / 5.0 2,697 Verified Reviews ♥ 21,071 Customer Favorites	 <b>Vehicle serviced</b> - Body electrical system checked
04/23/2009		D.C. Motor Vehicle Dept. Washington, DC Title #K1157834	<b>Registration issued or renewed</b>
06/02/2009		D.C. Inspection Station Washington, DC	<b>Passed emissions inspection</b>
02/24/2010	39,074	Circle Exxon Washington, DC 202-364-6364	 <b>Vehicle serviced</b> - Oil and filter changed
03/09/2010	40,438	Jim Coleman Toyota Bethesda, MD 301-469-7100 jimcolemantoyota.com ★ 4.7 / 5.0 2,697 Verified Reviews ♥ 21,071 Customer Favorites	 <b>Vehicle serviced</b> - Interior trim checked - Tire condition and pressure checked
06/18/2010	41,815	Circle Exxon Washington, DC 202-364-6364	 <b>Vehicle serviced</b> - Recommended maintenance performed - Brakes checked

- Fluids checked
- Oil and filter changed
- Tires rotated

06/28/2010

D.C.  
Motor Vehicle Dept.  
Washington, DC  
Title #K1157834

**Registration issued or renewed**

09/18/2010

44,086

Circle Exxon  
Washington, DC  
202-364-6364



**Vehicle serviced**

- Fluids checked
- Oil and filter changed
- Wiper(s) replaced

02/24/2011

Toyota Motor Sales, USA, Inc.

**Manufacturer Safety recall issued**

- NHTSA #11V113
- Recall #90L SAFETY RECALL 90L - POTENTIAL FLOOR MAT INTERFERENCE WITH ACCELERATOR PEDAL
- Status: Remedy Available

Locate an authorized Toyota dealer near you to schedule an appointment

[Learn more about this recall](#)

**Description:** Toyota is recalling certain model year 2008 through 2011 Lexus LX570, 2003 through 2009 Toyota 4Runner, and 2006 through 2010 Rav4 vehicles. The accelerator pedal can get stuck in the wide open position due to its being trapped by an unsecured or incompatible driver's floor mat.

A stuck open accelerator pedal may result in very high vehicle speeds and make it difficult to stop the vehicle, which could cause a crash, serious injury or death.

**Remedy:** The remedy is now available. The safety recall began early April 2011. The remedy will involve modification or replacement of the accelerator pedal and replacement of any Toyota all-weather floor mat. Owners may contact Toyota at 1-800-331-4331 or Lexus at 1-800-255-3987.

04/18/2011

46,747

Circle Exxon  
Washington, DC  
202-364-6364



**Vehicle serviced**

- Brakes checked
- Brakes serviced
- Front brake pads replaced
- Front brake rotor(s) replaced
- Oil and filter changed
- Tire(s) replaced
- Tires rotated

05/25/2011

D.C.  
Motor Vehicle Dept.  
Washington, DC  
Title #K1157834

**Registration issued or renewed**

05/21/2013

D.C.  
Inspection Station  
Washington, DC

**Passed emissions inspection**

05/23/2013

D.C.  
Motor Vehicle Dept.  
Washington, DC  
Title #K1157834

**Registration issued or renewed**

- Registration updated when owner moved the vehicle to a new location

03/31/2014

Toyota Motor Sales, USA, Inc.

**Manufacturer Service Campaign issued**

- Campaign #BST SPECIAL SERVICE CAMPAIGN (SSC) BST MULTIPLE MODEL AND MODEL YEARS SMART STOP TECHNOLOGY
- Status: Remedy Available

Locate an authorized Toyota dealer near you to schedule an appointment

[Learn more about this campaign](#)

**Description:** In our continuing effort to ensure the best in customer satisfaction, Toyota has converted Limited Service Campaign (LSC) BST into Special Service Campaign (SSC) BST with no expiration date.

**Remedy:** Toyota will install Smart Stop Technology on the involved model and model year vehicles. This feature will cut engine power in case of simultaneous application of both the accelerator and brake pedals at certain speeds and in certain driving conditions.

05/07/2015	D.C. Inspection Station Washington, DC	<b>Passed emissions inspection</b>
06/23/2015	D.C. Motor Vehicle Dept. Washington, DC Title #K1157834	<b>Registration issued or renewed</b>
02/02/2016	Toyota Motor Sales, USA, Inc.	<p><b>Manufacturer Safety recall issued</b></p> <ul style="list-style-type: none"> <li>- NHTSA #16V065</li> <li>- Recall #G0C SAFETY RECALL G0C - REMEDY NOTICE CERTAIN 2003-2006 LAND CRUISER CERTAIN 2004-2006 4RUNNER CERTAIN 2005-2006 SEQUOIA AND TUNDRA CURTAIN-SHIELD AIRBAG (CSA) AIRBAG CONTROL MODULE</li> <li>- Status: Remedy Available</li> </ul> <p>Locate an authorized Toyota dealer near you to schedule an appointment</p> <p><b>Learn more about this recall</b></p>
<p><b>Description:</b> The subject vehicles are equipped with side Curtain-Shield-Airbags (CSAs) which deploy from the roof rails in the event of certain types of crashes. Due to improper programing in the airbag control module, there is a possibility that, under certain specific and limited conditions shortly after vehicle startup, the CSAs and seat belt pre-tensioners could activate when not necessary.</p> <p>Unexpected activation of the CSAs could increase the risk of injury to the occupant.</p> <p><b>Remedy:</b> The remedy will consist of the replacement of the airbag control module.</p>		
06/14/2016	D.C. Motor Vehicle Dept. Washington, DC Title #K1157834	<b>Registration issued or renewed</b>
06/02/2017	D.C. Inspection Station Washington, DC	<b>Passed emissions inspection</b>
06/20/2017	D.C. Motor Vehicle Dept. Washington, DC Title #K1157834	<b>Registration issued or renewed</b>
05/23/2018	D.C. Motor Vehicle Dept. Washington, DC Title #K1157834	<b>Registration issued or renewed</b>
05/22/2019	D.C. Motor Vehicle Dept. Washington, DC Title #K1157834	<b>Registration issued or renewed</b> - Registration updated when owner moved the vehicle to a new location
05/29/2019	D.C. Inspection Station Washington, DC	<b>Passed emissions inspection</b>
06/03/2020	D.C. Motor Vehicle Dept. Washington, DC Title #K1157834	<b>Registration issued or renewed</b>
07/27/2020	Damage Report	<b>Damage reported: minor damage</b> - Damage to right front - Damage to right side

**CARFAX HAS THE MOST ACCIDENT & DAMAGE INFORMATION**

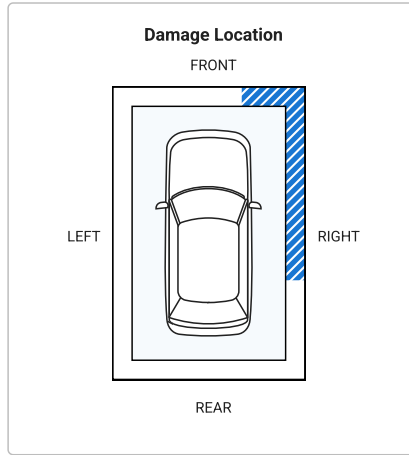
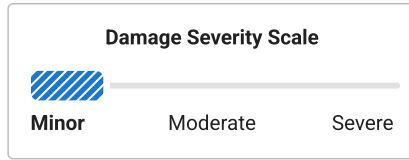

Minor damage is usually cosmetic, including dents or scratches to the vehicle body.

04/29/2021

D.C.  
Inspection Station  
Washington, DC

**Passed emissions inspection**

07/02/2021

Damage Report

**Damage reported: minor damage**

- Damage to right front
- Damage to right side
- Damage to front

**CARFAX HAS THE MOST ACCIDENT & DAMAGE INFORMATION**

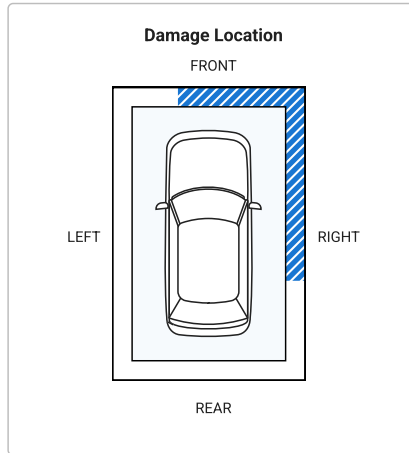
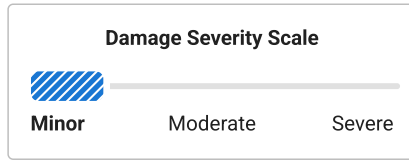

06/07/2022

D.C.  
Motor Vehicle Dept.  
Washington, DC  
Title #K1157834

**Registration issued or renewed**

04/26/2023

D.C.  
Inspection Station  
Washington, DC

**Passed emissions inspection**

12/06/2023

D.C.  
Motor Vehicle Dept.

**Registration updated when owner moved the vehicle to a new location**

Washington, DC

04/25/2024

D.C.  
Motor Vehicle Dept.  
Washington, DC  
Title #K1157834

Registration issued or renewed

08/01/2024

Damage Report

Damage reported: minor damage  
- Damage to rear

CARFAX HAS THE MOST  
ACCIDENT & DAMAGE  
INFORMATION

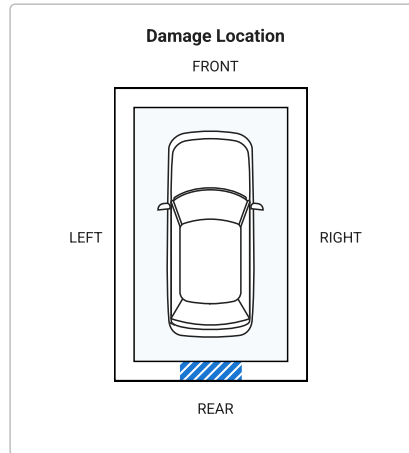
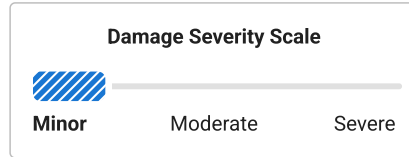

09/18/2024

114,394

Chevy Chase Acura  
Bethesda, MD  
301-657-4000  
chevychaseacura.com



Vehicle serviced

★ 4.7 / 5.0 1,238 Verified Reviews

♥ 9,082 Customer Favorites

Have Questions? Consumers, please visit our Help Center at [www.carfax.com](http://www.carfax.com). Dealers or Subscribers, please visit our Help Center at [www.carfaxonline.com](http://www.carfaxonline.com).

## CARFAX Glossary

### Damage Indicator

Damage can be a result of many different types of events. Examples include contact with objects (other cars, trees, traffic signs, road debris, etc), vandalism, or weather-related events. Not every damage event is reported to CARFAX. As details about the damage event become available, those additional details are added to the CARFAX Vehicle History Report. CARFAX recommends that you have this vehicle inspected by a qualified mechanic.

- This CARFAX Vehicle History Report is based only on information supplied to CARFAX and available as of 4/6/26 at 2:16:37 PM (CDT). Other information about this vehicle, including problems, may not have been reported to CARFAX. Use this report as one important tool, along with a vehicle inspection and test drive, to make a better decision about your next used car.

### Damage Severity

Damage events result in one of the following severity levels:

- Minor: Generally, minor damage is cosmetic (including dents or scratches), may only require reconditioning, and typically does not compromise a vehicle's operation and/or safety.
- Moderate: Moderate damage may affect multiple components of the vehicle and may impair the vehicle's operation and/or safety.
- Severe: Severe damage usually affects multiple components of the vehicle and is likely to compromise the vehicle's operation and/or safety.

CARFAX recommends getting a pre-purchase inspection at a certified collision repair facility.

### First Owner

When the first owner(s) obtains a title from a Department of Motor Vehicles as proof of ownership.

### Manufacturer Recall

Automobile manufacturers issue recall notices to inform vehicle owners of a safety defect or failure to meet minimum federal safety or emissions standards. Manufacturer recalls are repaired at no cost to the customer.

### Ownership History

CARFAX defines an owner as an individual or business that possesses and uses a vehicle. Not all title transactions represent changes in ownership. To provide estimated number of owners, CARFAX proprietary technology analyzes all the events in a vehicle history. Estimated ownership is available for vehicles manufactured after 1991 and titled solely in the US including Puerto Rico. Dealers sometimes opt to take ownership of a vehicle and are required to in the

following states: Maine, Massachusetts, New Jersey, Ohio, Oklahoma, Pennsylvania and South Dakota. Please consider this as you review a vehicle's estimated ownership history.

**Service Campaign**



Automobile manufacturers issue a service campaign to address product technical issues that may not be related to safety or emissions standards. These issues are typically customer satisfaction initiatives.

**Title Issued**

A state issues a title to provide a vehicle owner with proof of ownership. Each title has a unique number. Each title or registration record on a CARFAX report does not necessarily indicate a change in ownership. In Canada, a registration and bill of sale are used as proof of ownership.

**Toyota Recall / Service Campaign**

Portions of this report have been included under license from Toyota Motor North America, Inc. ("TOYOTA"), License Agreement TMS1013 . This data applies only to vehicle marketed or originally sold in Mexico and the United States of America, including Guam, Saipan, American Samoa, Puerto Rico, the U.S. Virgin Islands and the other United States territories and protectorates with currently open safety or emissions recalls, or service campaigns. While TOYOTA provides data to Carfax Inc. on a regular basis, this report may not include very recent activity. For the manufacturer's most current information on recall/campaign activity for any Toyota, Lexus or Scion brand vehicle, you must go to <http://toyota.com/recall> or <http://lexus.com/recall>.

Follow Us:  [facebook.com/CARFAX](https://facebook.com/CARFAX)  [@CARFAXinc](https://twitter.com/CARFAXinc)  [About CARFAX](#)

CARFAX DEPENDS ON ITS SOURCES FOR THE ACCURACY AND RELIABILITY OF ITS INFORMATION. THEREFORE, NO RESPONSIBILITY IS ASSUMED BY CARFAX OR ITS AGENTS FOR ERRORS OR OMISSIONS IN THIS REPORT. CARFAX FURTHER EXPRESSLY DISCLAIMS ALL WARRANTIES, EXPRESS OR IMPLIED, INCLUDING ANY IMPLIED WARRANTIES OF MERCHANTABILITY OR FITNESS FOR A PARTICULAR PURPOSE.

© 2026 CARFAX, Inc., part of S&P Global. All rights reserved.  
4/6/26 2:16:37 PM (CDT)

**I have reviewed and received a copy of the CARFAX Vehicle History Report for this 2004 TOYOTA 4RUNNER vehicle (VIN: JTEBU17R748022474), which is based on information supplied to CARFAX and available as of 4/6/26 at 3:16 PM (EDT).**

\_\_\_\_\_  
Customer Signature

\_\_\_\_\_  
Date

\_\_\_\_\_  
Dealer Signature

\_\_\_\_\_  
Date