

Display CARFAX in online listings:



History-Based Value Report

History events affecting this vehicle's value



1

1-Owner Vehicle



Minor Damage

\$10,840 Retail Value



Vehicle History Report™

US \$44.99

**2015 FORD EXPLORER
POLICE INTERCEPTOR
UTILITY**

VIN: 1FM5K8AR5FGB26023
4 DOOR WAGON/SPORT
UTILITY
3.7L V6 F DOHC 24V
GASOLINE
FRONT WHEEL DRIVE W/ 4X4
Original Window Sticker

Accident reported: minor damage

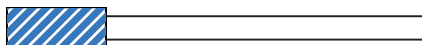

MINOR MODERATE SEVERE



1 Service history record



CARFAX 1-Owner vehicle





Last owned in Michigan





103,275 Last reported odometer reading

This CARFAX Vehicle History Report is based only on information supplied to CARFAX and available as of 6/18/23 at

7:00:51 AM (CDT). Other information about this vehicle, including problems, may not have been reported to CARFAX. Use this report as one important tool, along with a vehicle inspection and test drive, to make a better decision about your next used car.

 Ownership History The number of owners is estimated		Owner 1
Year purchased		2014
Type of owner		---
Estimated length of ownership		8 yrs. 6 mo.
Owned in the following states/provinces		Michigan
Estimated miles driven per year		13,547/yr
Last reported odometer reading		103,275

 Title History CARFAX guarantees the information in this section		Owner 1
Damage Brands Salvage Junk Rebuilt Fire Flood Hail Lemon		<input checked="" type="checkbox"/> Guaranteed No Problem
Odometer Brands Not Actual Mileage Exceeds Mechanical Limits		<input checked="" type="checkbox"/> Guaranteed No Problem
 GUARANTEED - None of these major title problems were reported by a state Department of Motor Vehicles (DMV). If you find that any of these title problems were reported by a DMV and not included in this report, CARFAX will buy this vehicle back. View Terms View Certificate		

 Additional History Not all accidents / issues are reported to CARFAX		Owner 1
Total Loss No total loss reported to CARFAX.		<input checked="" type="checkbox"/> No Issues Reported
Structural Damage CARFAX recommends that you have this vehicle inspected by a collision repair specialist.		<input checked="" type="checkbox"/> No Issues Reported
Airbag Deployment No airbag deployment reported to CARFAX.		<input checked="" type="checkbox"/> No Issues Reported
Odometer Check No indication of an odometer rollback.		<input checked="" type="checkbox"/> No Issues Indicated
Accident / Damage Accidents reported: 06/26/2016, 05/11/2018, and 08/05/2019.		Minor Damage

Manufacturer Recall	A current list of recalls is available at Ford Motor Company.	<input checked="" type="checkbox"/> No Recalls Reported
Basic Warranty	Original warranty estimated to have expired.	Warranty Expired

CARFAX Detailed History





Owner 1
Purchased: 2014

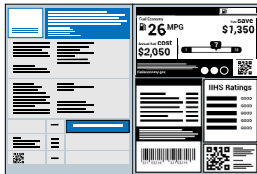

Low mileage! This owner drove less than the industry average of 15,000 miles per year.

13,547 mi/yr

Date	Mileage	Source	Comments
11/13/2014		Ford Motor Company	<p>Vehicle manufactured and shipped to original dealer</p>  <p>Original Window Sticker</p>
11/25/2014	14	Michigan Motor Vehicle Dept. Saint Joseph, MI Title #208C3290230	<p>Title issued or updated First owner reported</p>
06/26/2016		Damage Report	 <p>Accident reported: minor damage It hit a deer It hit an animal Damage to front Airbags did not deploy</p>



CARFAX HAS THE MOST ACCIDENT & DAMAGE INFORMATION

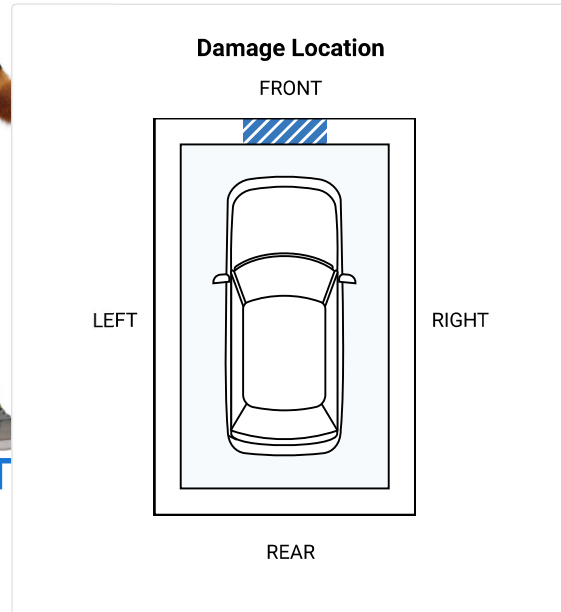

Minor damage is usually cosmetic, including dents or scratches to the vehicle body.

10/02/2017

Ford Motor Company

Manufacturer Customer Satisfaction Program issued
 Program #17M06 CANISTER PURGE VALVE LEAKS

Locate an authorized Ford or Lincoln dealer or call 866-436-7332 to obtain more information

05/11/2018

Damage Report



Accident reported: minor damage
 Damage to left rear



CARFAX HAS THE MOST ACCIDENT & DAMAGE INFORMATION

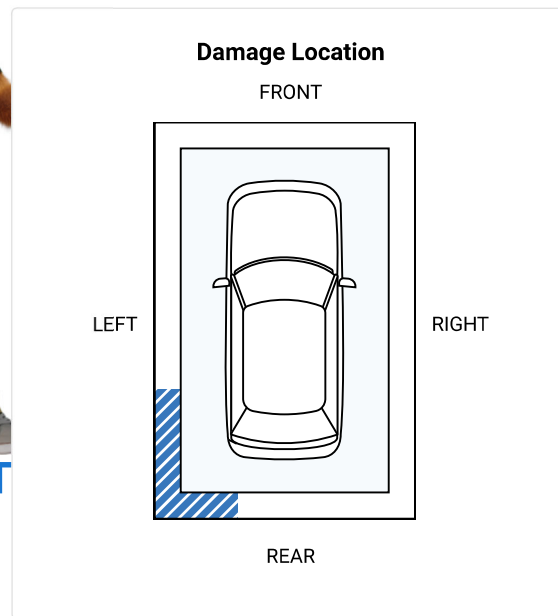
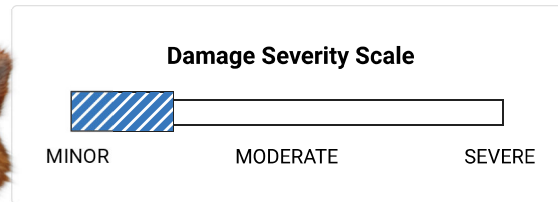

08/05/2019

Damage Report



Accident reported: minor damage
Damage to rear



CARFAX HAS THE MOST ACCIDENT & DAMAGE INFORMATION

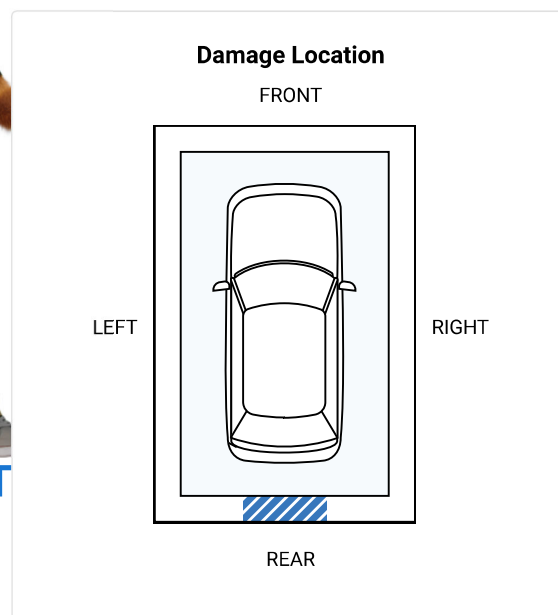
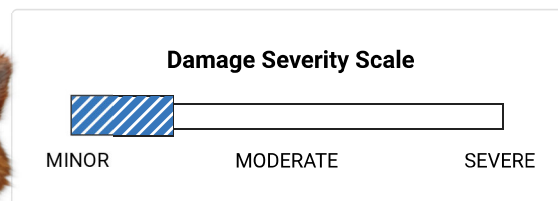

07/08/2022 103,275 Seelye Ford of
Kalamazoo
Kalamazoo, MI
888-568-6231
seelyefordkalamazoo.co
m



Vehicle serviced
Starter replaced

★ 4.7 / 5.0

270 Verified Reviews

♥ 5,212 Customer
Favorites

07/12/2022

Ford Motor Company

**Manufacturer Customer Satisfaction
Program issued**

Program #22N01 REAR WHEEL
KNUCKLE REPLACEMENT

Locate an authorized Ford or Lincoln
dealer or call 866-436-7332 to obtain
more information

Have Questions? Consumers, please visit our Help Center at www.carfax.com. Dealers or
Subscribers, please visit our Help Center at www.carfaxonline.com.



Glossary

Accident Indicator

CARFAX receives information about accidents in all 50 states, the District of Columbia and Canada.

Not every accident is reported to CARFAX. As details about the accident become available, those additional details are added to the CARFAX Vehicle History Report. CARFAX recommends that you have this vehicle inspected by a qualified mechanic.

- According to the National Safety Council, Injury Facts, 2021 edition, 5% of the 276 million registered vehicles in the U.S. were involved in an accident in 2019. Over 77% of these were considered minor or moderate.
- This CARFAX Vehicle History Report is based only on information supplied to CARFAX and available as of 6/18/23 at 7:00:51 AM (CDT). Other information about this vehicle, including problems, may not have been reported to CARFAX. Use this report as one important tool, along with a vehicle inspection and test drive, to make a better decision about your next used car.

Damage Severity

Damage events result in one of the following severity levels:

- **Minor:** Generally, minor damage is cosmetic (including dents or scratches), may only require reconditioning, and typically does not compromise a vehicle's operation and/or safety.
- **Moderate:** Moderate damage may affect multiple components of the vehicle and may impair the vehicle's operation and/or safety.
- **Severe:** Severe damage usually affects multiple components of the vehicle and is likely to compromise the vehicle's operation and/or safety.

CARFAX recommends getting a pre-purchase inspection at a certified collision repair facility.

First Owner

When the first owner(s) obtains a title from a Department of Motor Vehicles as proof of ownership.

Ford or Lincoln Mercury Recall

The Ford Motor Company provides CARFAX with Field Service Action and recall information regarding safety, compliance and emissions programs announced since 2000 for a specific vehicle. For complete information regarding programs or concerns about this vehicle, please contact a local Ford or Lincoln Mercury Dealer.

Ownership History

CARFAX defines an owner as an individual or business that possesses and uses a vehicle. Not all title transactions represent changes in ownership. To provide estimated number of owners, CARFAX proprietary technology analyzes all the events in a vehicle history. Estimated ownership is available for vehicles manufactured after 1991 and titled solely in the US including Puerto Rico. Dealers sometimes opt to take ownership of a vehicle and are required to in the following states: Maine, Massachusetts, New Jersey, Ohio, Oklahoma, Pennsylvania and South Dakota. Please consider this as you review a vehicle's estimated ownership history.

Title Issued

A state issues a title to provide a vehicle owner with proof of ownership. Each title has a unique number. Each title or registration record on a CARFAX report does not necessarily indicate a change in ownership. In Canada, a registration and bill of sale are used as proof of ownership.

Follow Us:



facebook.com/CARFAX



[@CARFAXinc](https://twitter.com/CARFAXinc)



About CARFAX

CARFAX DEPENDS ON ITS SOURCES FOR THE ACCURACY AND RELIABILITY OF ITS INFORMATION. THEREFORE, NO RESPONSIBILITY IS ASSUMED BY CARFAX OR ITS AGENTS FOR ERRORS OR OMISSIONS IN THIS REPORT. CARFAX FURTHER EXPRESSLY DISCLAIMS ALL WARRANTIES, EXPRESS OR IMPLIED, INCLUDING ANY IMPLIED WARRANTIES OF MERCHANTABILITY OR FITNESS FOR A PARTICULAR PURPOSE.

© 2023 CARFAX, Inc., part of S&P Global. All rights reserved.
6/18/23 7:00:51 AM (CDT)

I have reviewed and received a copy of the CARFAX Vehicle History Report for this 2015 FORD EXPLORER vehicle (VIN: 1FM5K8AR5FGB26023), which is based on information supplied to CARFAX and available as of 6/18/23 at 8:00 AM (EDT).

Customer Signature

Date

Dealer Signature

Date